



We can realize, what nobody can promise you
RESEARCH – DEVELOPMENT - DESIGN

LOCATION



Contact: **E.mail: info@mdbdesign.sk**

Ing. Martin GERMAN t.č.+421 902 251 813 **E.mail: mgerman@mdbdesign.sk**

Ing. Roman JAKUB t.č.+421 911 382 240 **E.mail: rjakub@mdbdesign.sk**

www.mdbdesign.sk, www.mdbdesidn.eu, Website under construction

1., Software

drawing - 2D - Turbo CAD – similar to AutoCAD, dwg, dxf format
- number of licencies– 5ks

drawing - 3D - ProEngineer – Creo 3.0, 2.0 (older version of Creo from PTC as well)

- licencies – 5ks

- Creo Essentials Team – 1ks (floating licence)

- Creo Essentials Lite – 4ks

Calulation – Proe Mechanica

- licencies – 1ks

Document - Office app. – 5ks

Antivirus software- ESET Endpoint Security – 5ks

- ESET File Security for Microsoft Wind. Server - 1ks

OS – Win7 Profesional, Win Server 2011

2., Hardware

Dell Precision T5400 – 3ks - professional work CAD station for CAD

HP Workstation Z440 – 2ks - professional work CAD station for CAD

HP ProLiant MicroServer G7 – 1ks

- 1., Redesign of steel superstructure drawing documentation (or other designs) into the shop drawing documentation of design according to STN, ČSN, DIN, EN and redrawing paper versions into 2D and 3D formats according to Coostumer Standards.
- 2., „Inch“ drawing conversion to SI system according to STN, ČSN, DIN, EN and redrawing paper versions into 2D and 3D formats.
- 3., Single purpose devices – test stand
- 4., Delivery of individual designed units in cooperation with subcontractors, component manufacturers according to our production documentation:
 - including the wiring of electrical systems
 - including the involvement of pneumatic systems
 - including the involvement of pneumatic systems
 - including programming
- 5., Delivery of complete lines including robots and manipulators. KUKA, ABB robots, if required, from other manufacturers
- 6., Robotized workplace design : handling workplace, assembling workplace, inspection (diagnostic) workplace

7., Pneumatic systems.

8., Electric systems .

9., Hydraulic systems.

- opened circuit

- closed circuit

10., Stress analysis – FEM

11., Spare parts catalogues 2D, 3D.

12., Creation of operating instructions

13., Creating of other accompanying documentation.

14., Optimization and modernization of machinery and equipment in terms of functionality, production, changes to the materials, optimization in terms of allowagle stress.

15., Workplace analysis and inovation

16., Design of vehicle superstructures, trailers and semitrailers

- Gully-empty vehicles
- Universal combined superstructures
- concrete mixer
- water transportation
- transportation of fuel acc to ADR
- transportation of dangerous loads acc to ADR
- lowbed vehicles
- recovery vehicles

REFERENCES



- 1., AMT Servis s.r.o. - VALEO
- 2., VUKOV EXTRA a.s.
- 3., BSH Drives and Pumps s.r.o.
- 4., VIPO a.s.
- 5., U.S.Steel Košice, s.r.o.
- 6., LANÁ a.s.
- 7., PROTEO, spol. s r.o.
- 8., Slovfinco s.r.o.
- 9., TAES s.r.o.
- 10., TC CONTACT, spol. s r.o.
- 11., WHIRPOOL SLOVAKIA, spol. s r.o.
- 12., VACUUMSCHMELZE, s.r.o.
- 13., ANTEC - Freudenberg
- 14., ANTEC - AOKI
- 15., ANTEC - NISSENS
- 16., AUSYS s.r.o.
- 17., LANÁ, a.s.
- 18., AsfP, s.r.o.

AMT SERVIS ,s.r.o. – VALEO : CONNECTORS ASSEMBLING AND TESTING LINE – TYPE 1

MDR
DESIGN
DESIGN

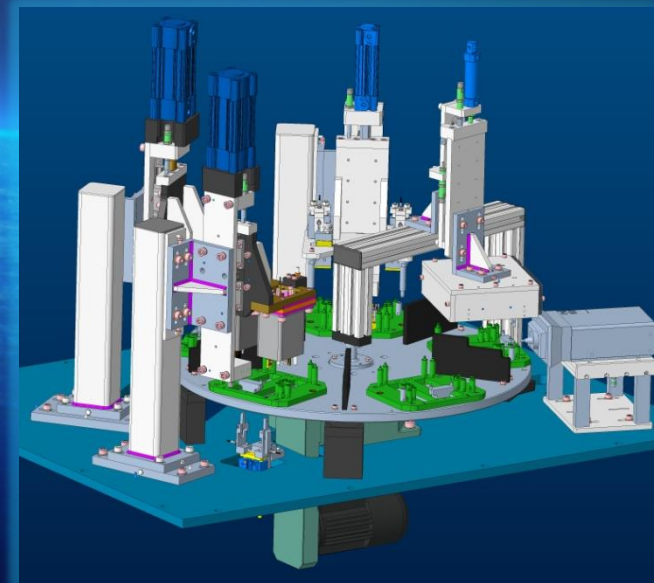
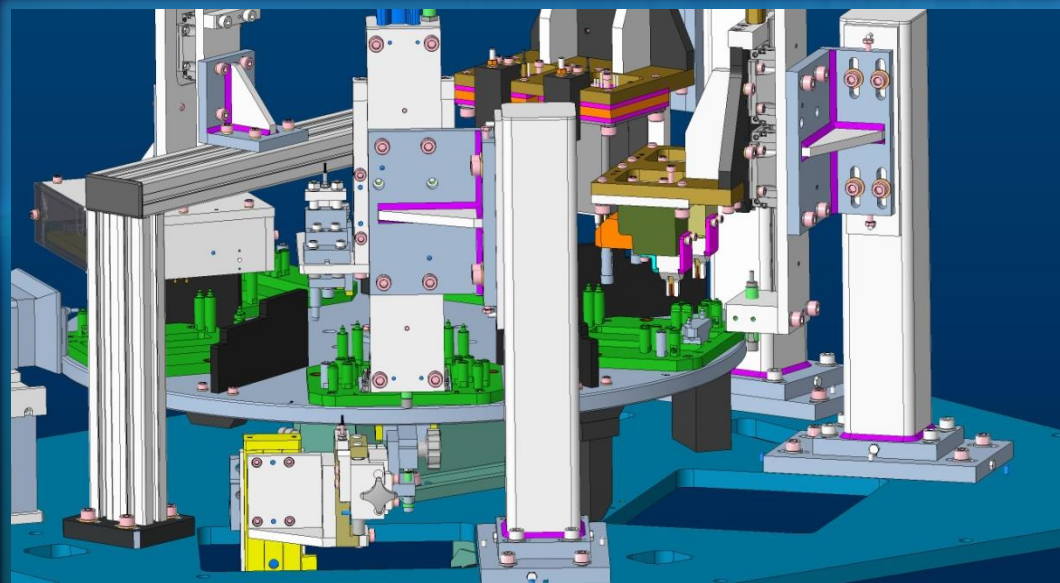
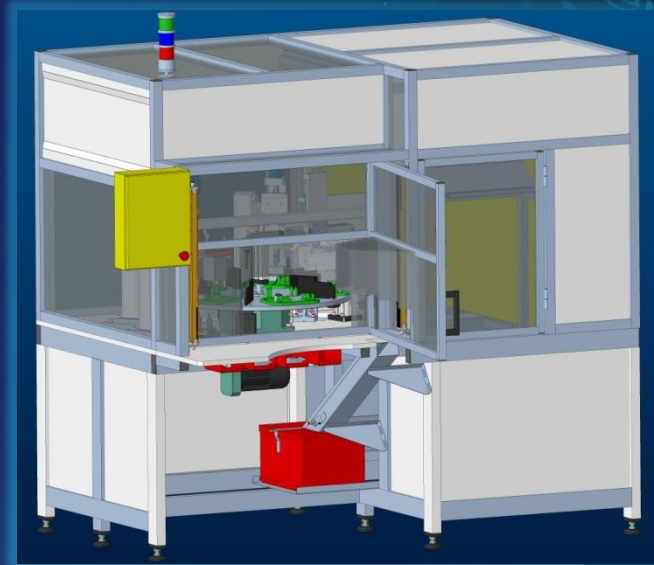
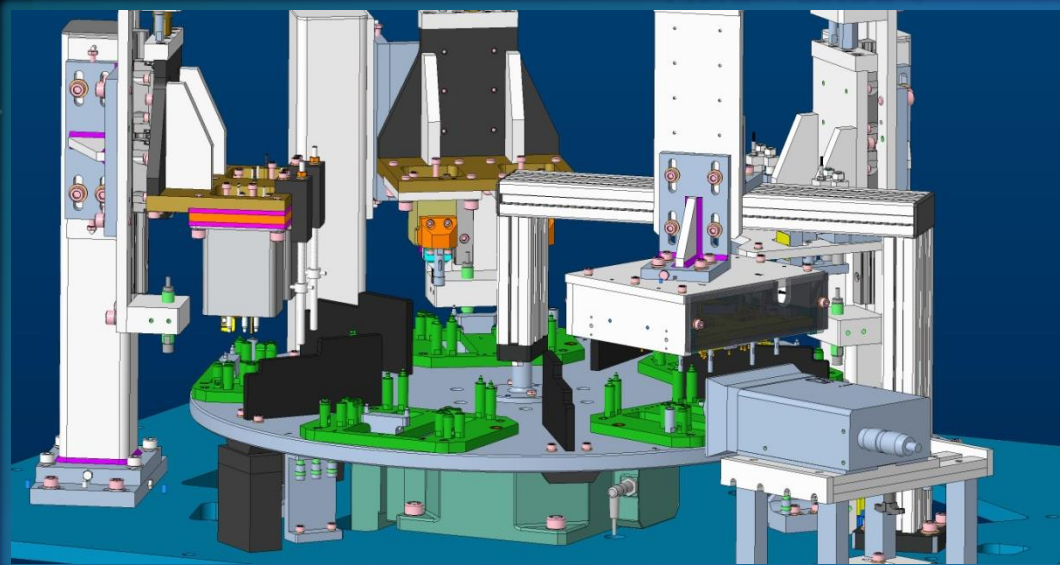

AMT SERVIS ,s.r.o. – VALEO : CONNECTORS ASSEMBLING AND TESTING LINE – TYPE 2

MDB
DESIGN
DESIGN

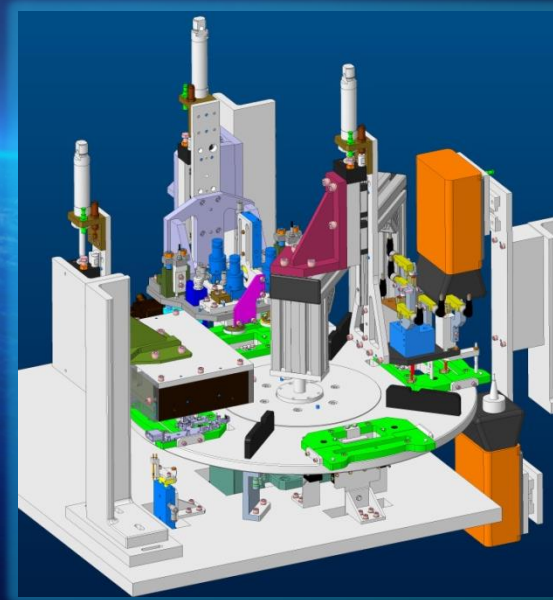
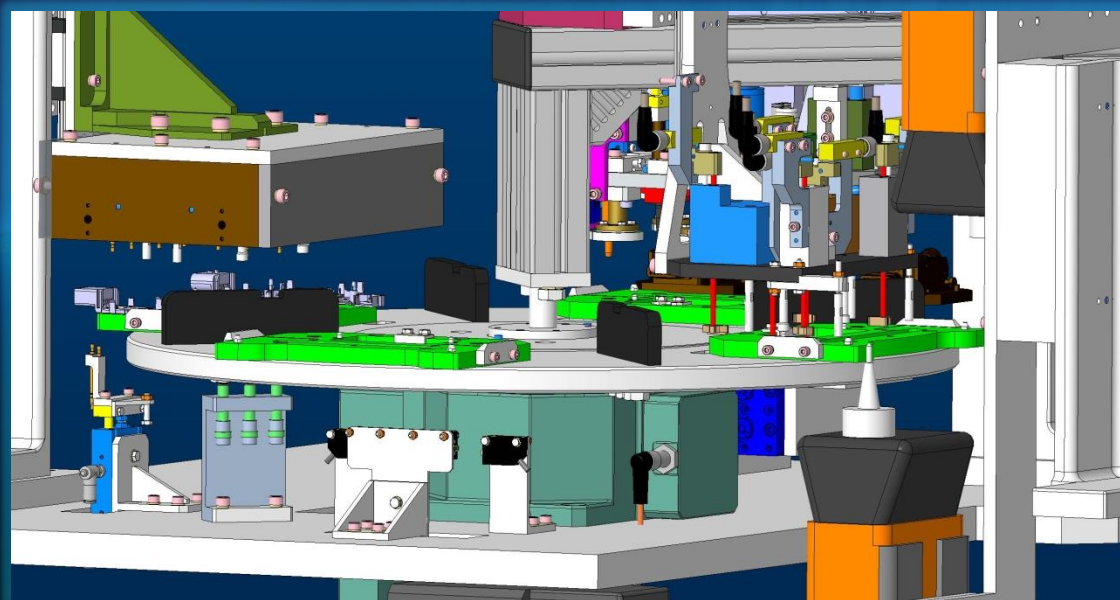
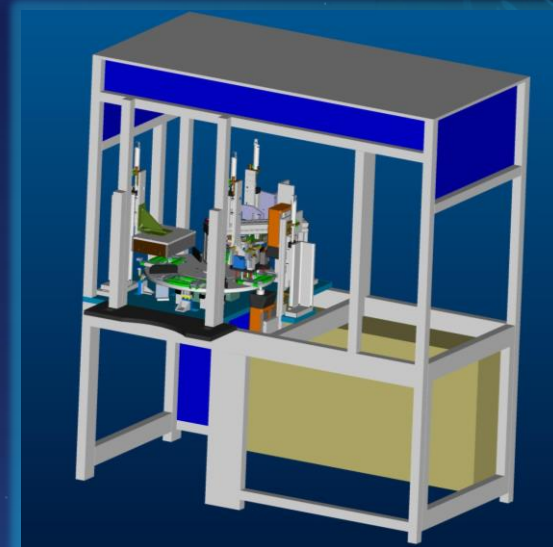

VACUUMSCHMELZE s.r.o. – SEMI-AUTOMATIC EQUIPMENT OF ADHESIVE TAPE TO SENSOR CARRIER SST - PERFORMANCE INCREASE BY 40%

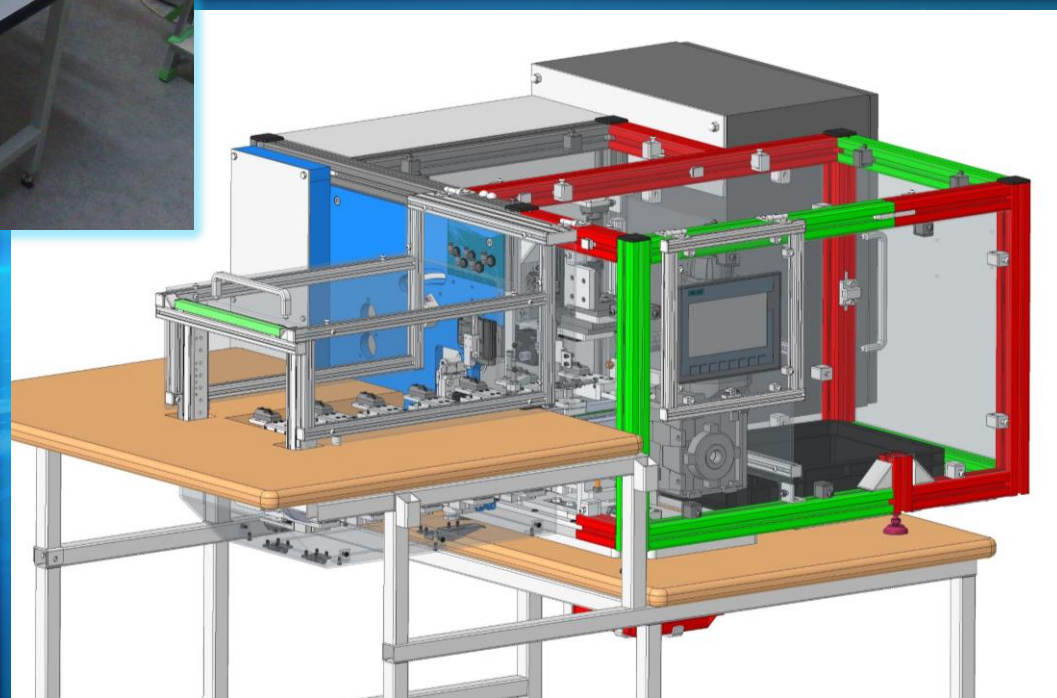
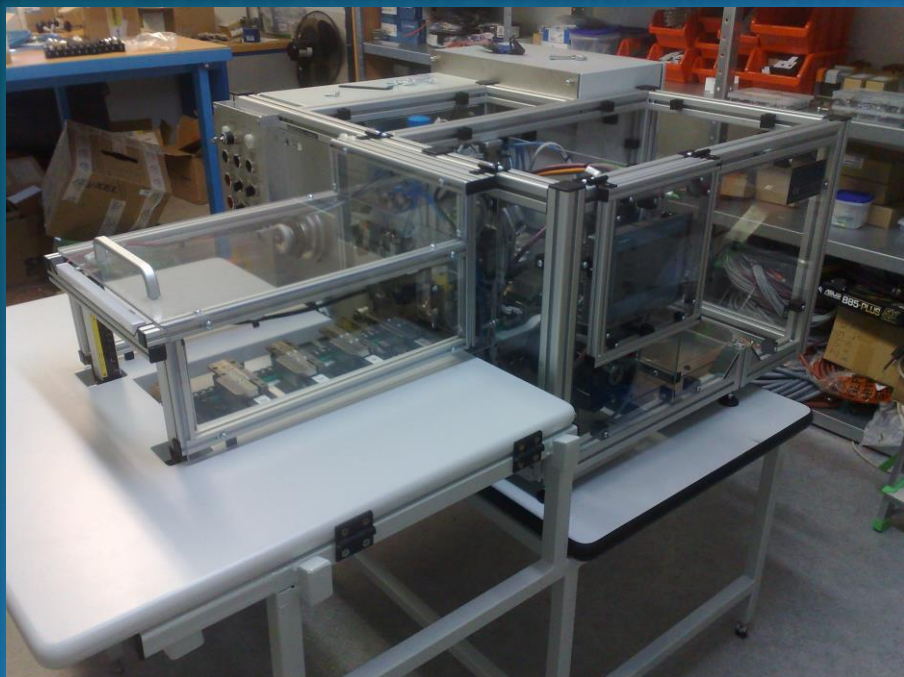

VACUUMSCHMELZE s.r.o. – FULLAUTOMATIC LINE FOR THE PRODUCTION
OF ADHESIVE BOUNDS - LIPS

MDB
DESIGN
DESIGN

OF ADHESIVE BOUNDS - LIPS

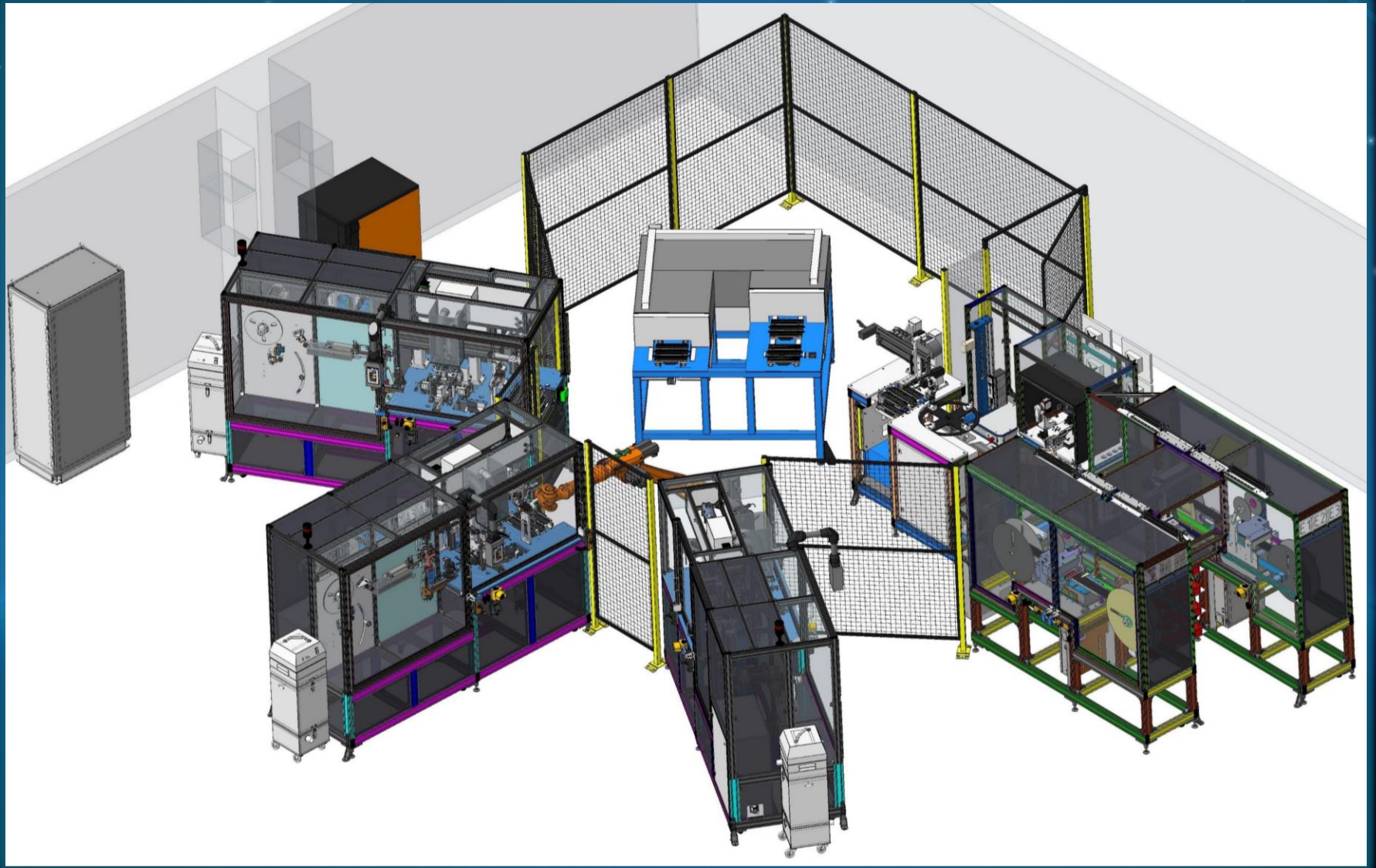

VACUUMSCHMELZE s.r.o. – FULLAUTOMATIC LINE FOR THE PRODUCTION
OF ADHESIVE BOUNDS - LIPS



OF ADHESIVE BOUNDS - LIPS



VACUUMSCHMELZE s.r.o. – FULLAUTOMATIC LINE FOR THE PRODUCTION OF ADHESIVE BOUNDS - LIPS

MDB
DESIGN
DESIGN

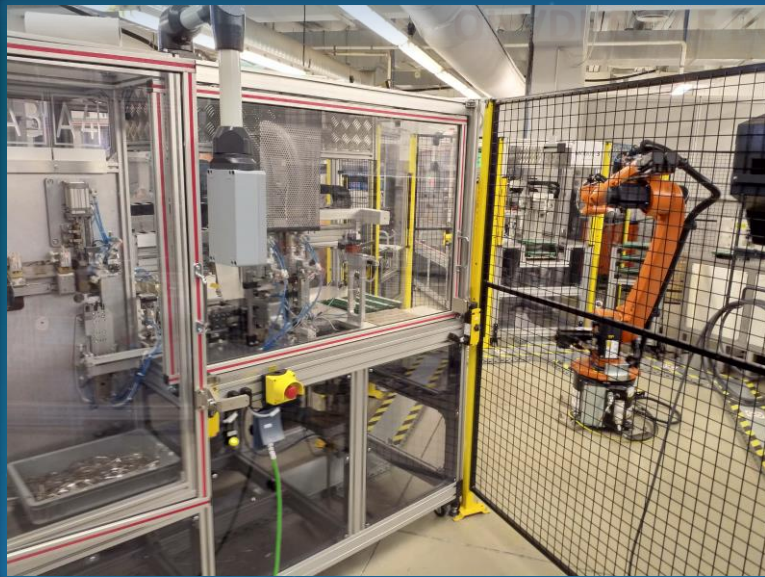

TAES s.r.o. - REALIZED WORKSTATIONS

MDB
DESIGN
DESIGN

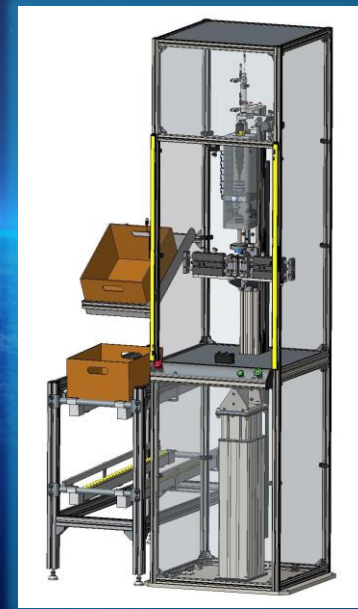
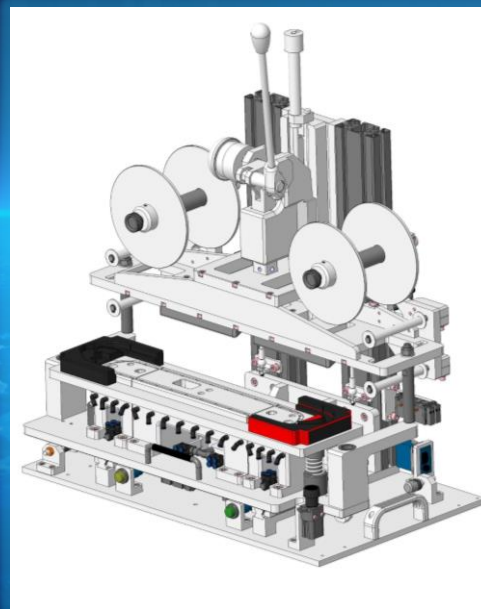
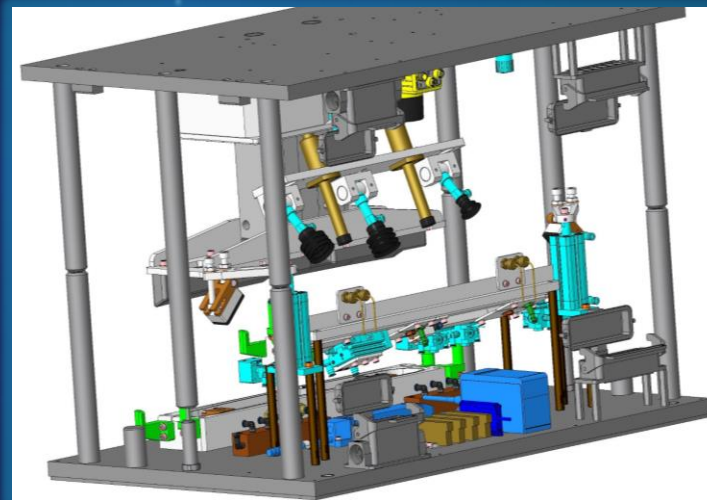

VUKOV EXTRA a.s. – WAGON WHEELSETS TRANSFER LINE

MDR
DESIGN
DESIGN

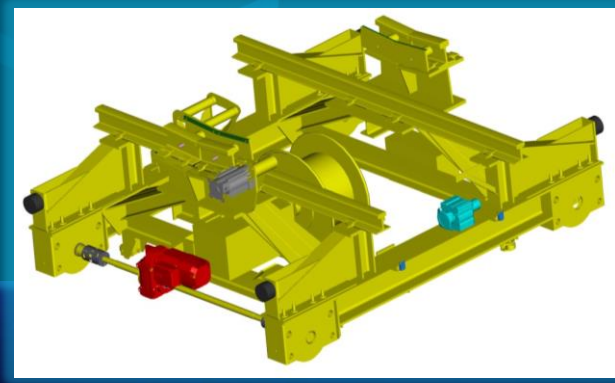
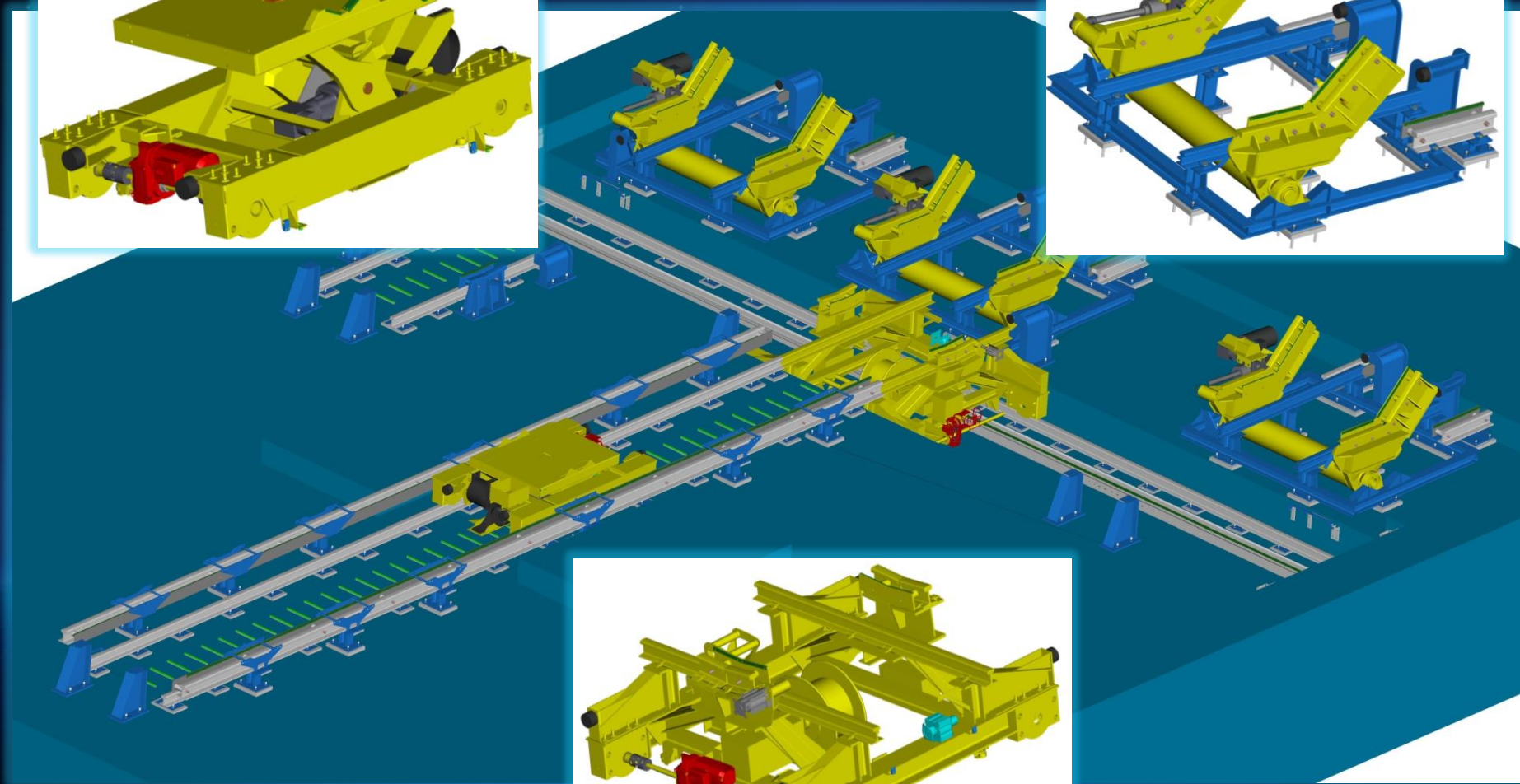
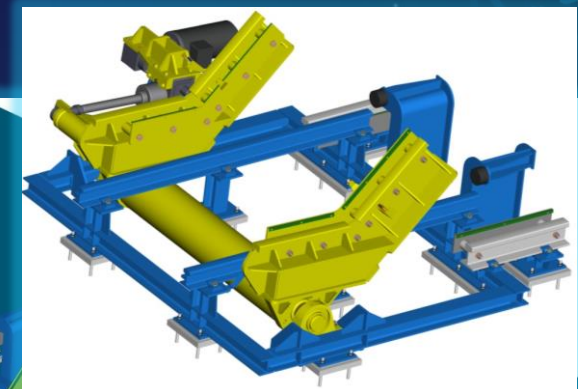
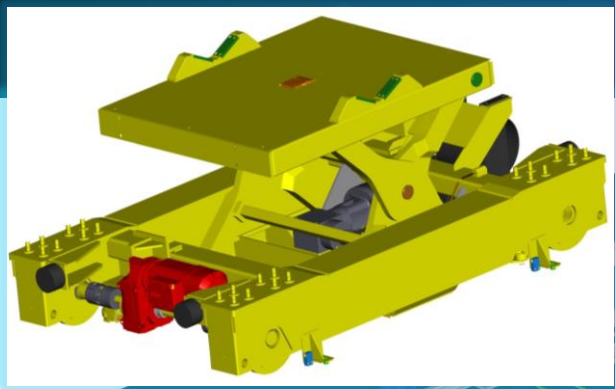

VUKOV EXTRA a.s. – WAGON WHEELSETS TRANSFER LINE

MDB
DESIGN
DESIGN



**BSH Drives and Pumps s.r.o. - BEARING LIFETIME TESTING STAND.
POSSIBILITY TO SET UP 7 DIFFERENT INDEPENDENT MOVEMENTS**

MDR
DESIGN
DESIGN

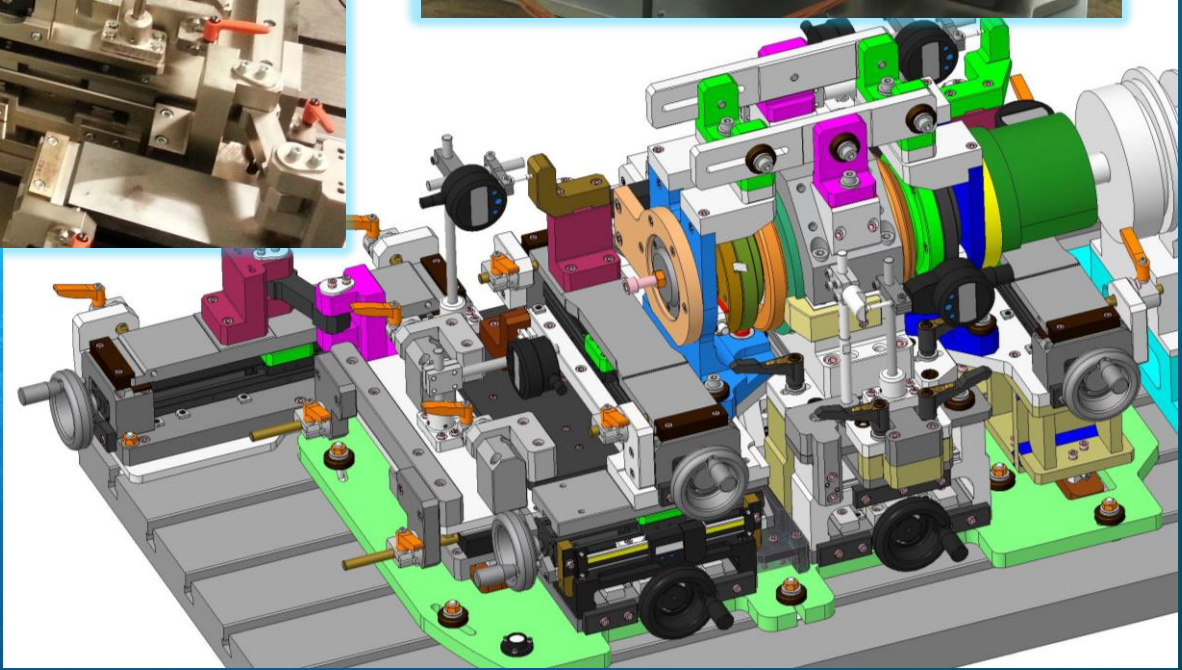
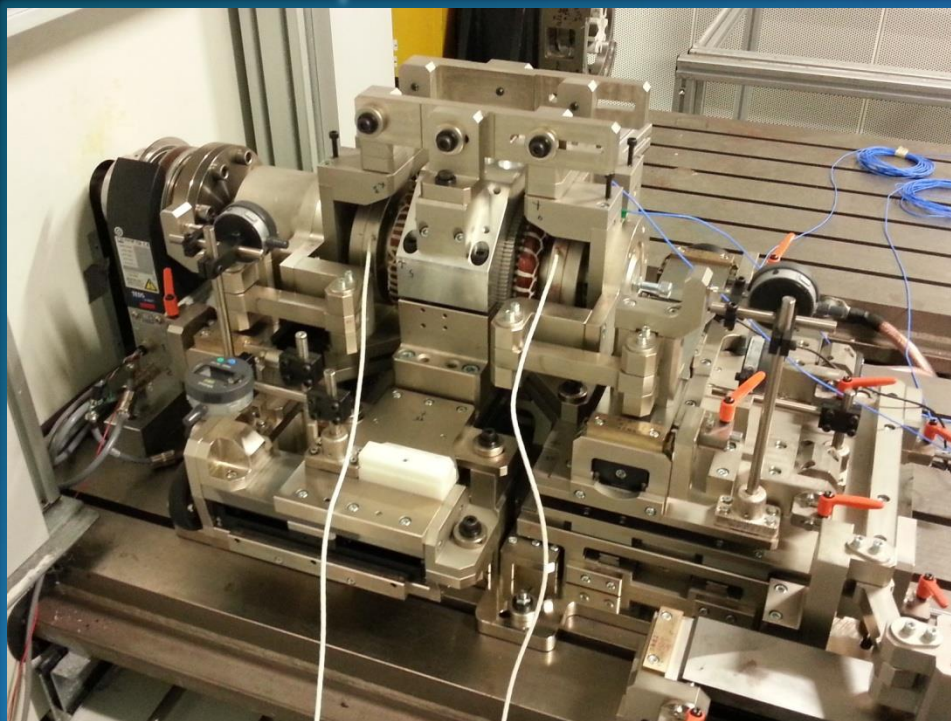

BSH Drives and Pumps s.r.o. - BEARINGS 10YEARS LIFETIME TESTING STAND

MDR
DESIGN
DESIGN

21/1/10

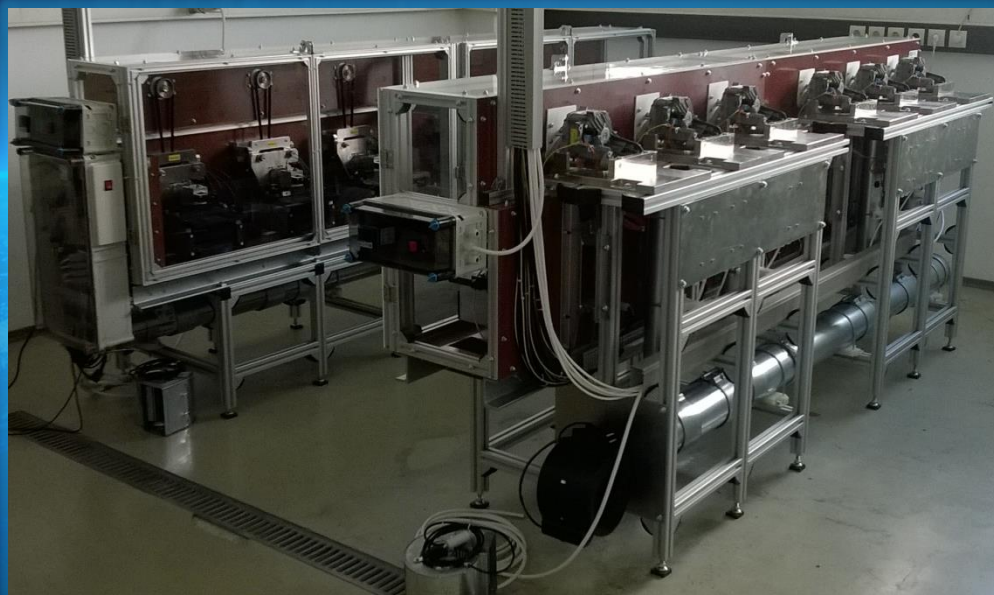
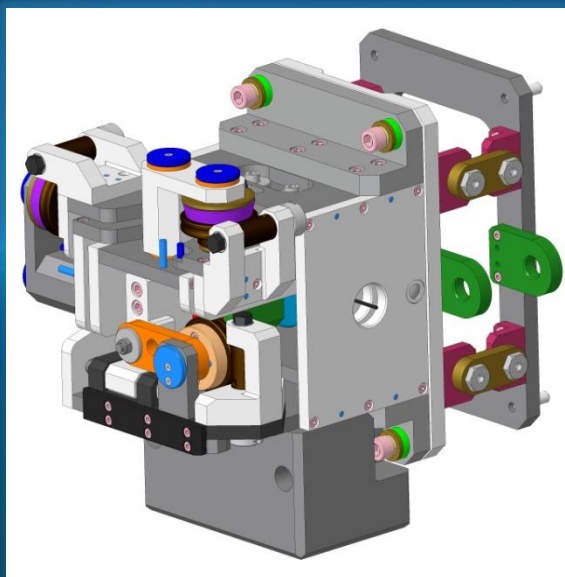
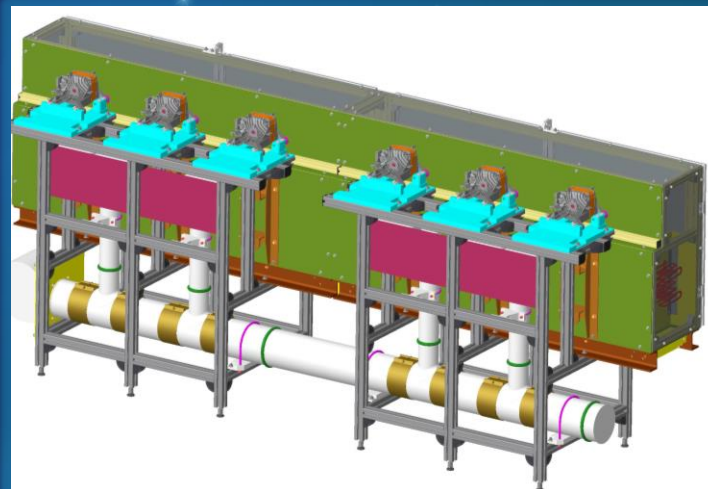
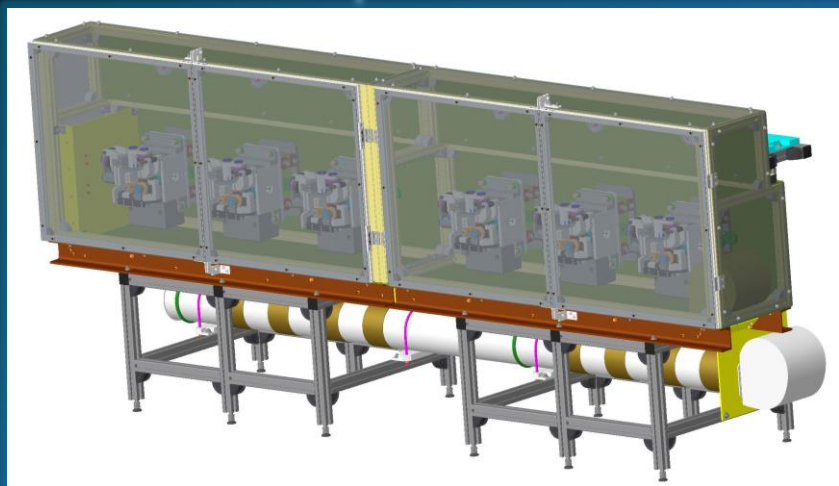

BSH Drives and Pumps s.r.o. – TESTING EQUIPMENT FOR SIMULATION OF FREQUENCY OF ELECTRIC MOTOR PACKAGE

MDB
DESIGN
DESIGN

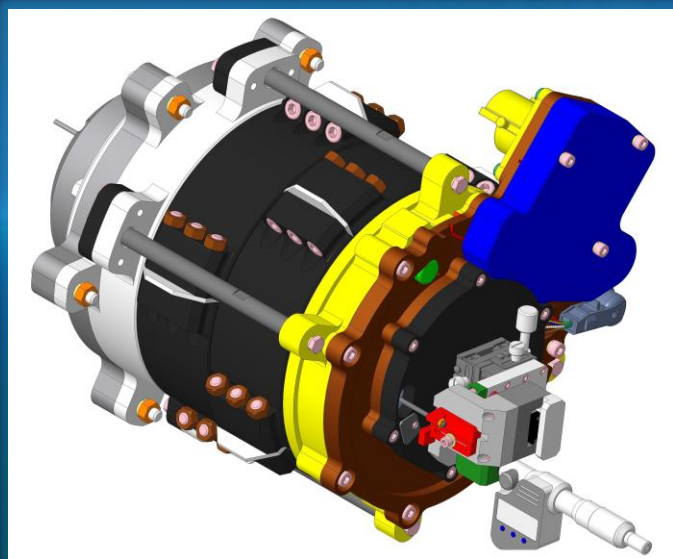
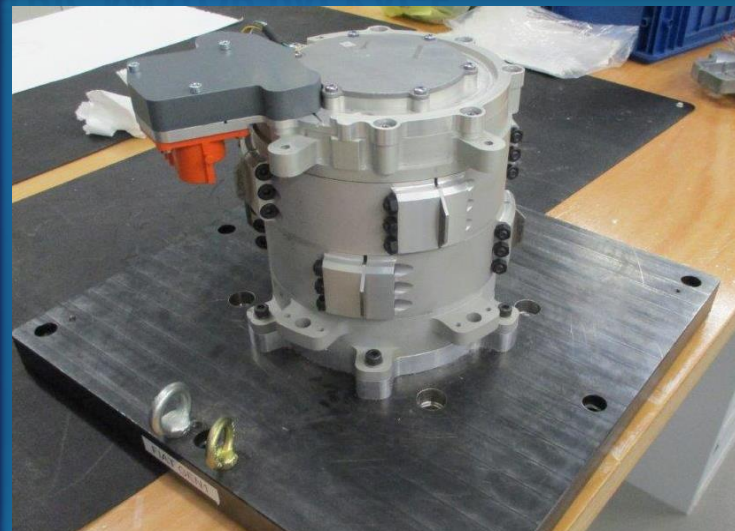
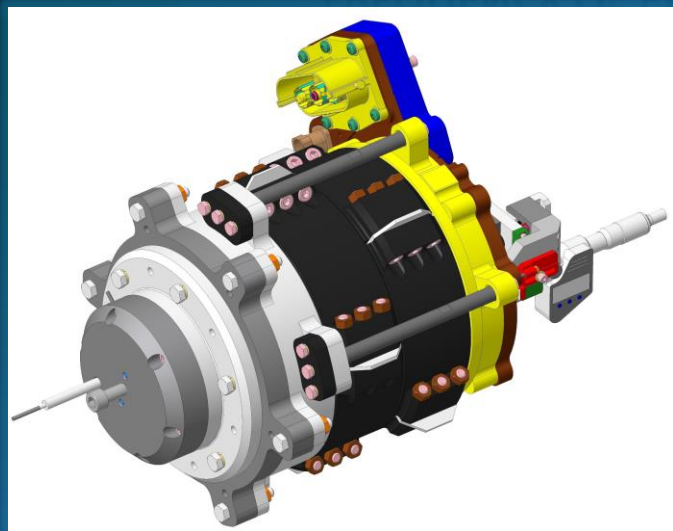

ANTEC – FREUDENBERG : SAW FOR CONTINUOUS FILTER DIVISION

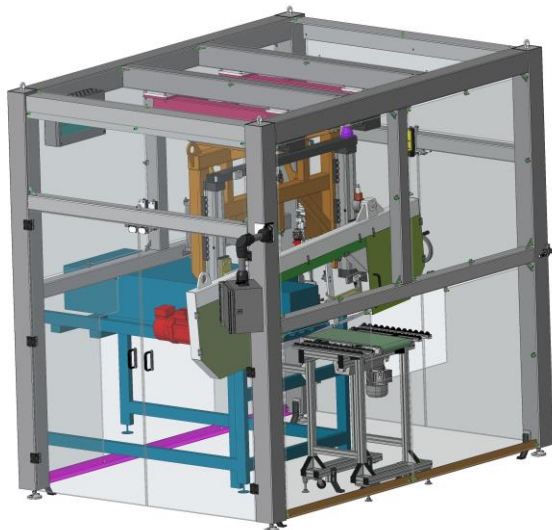
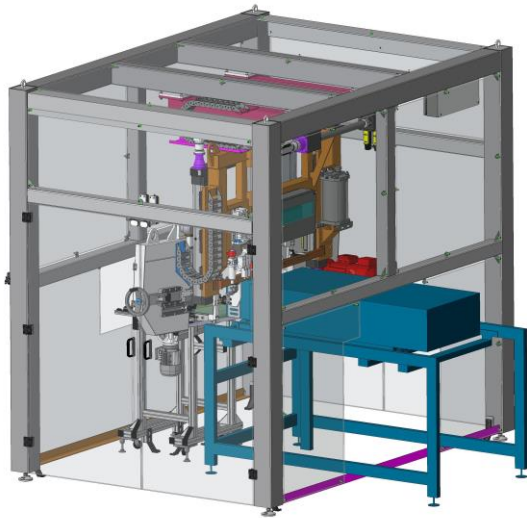

ANTEC – AOKI : LASER MARKING AND PISTON CONTROL

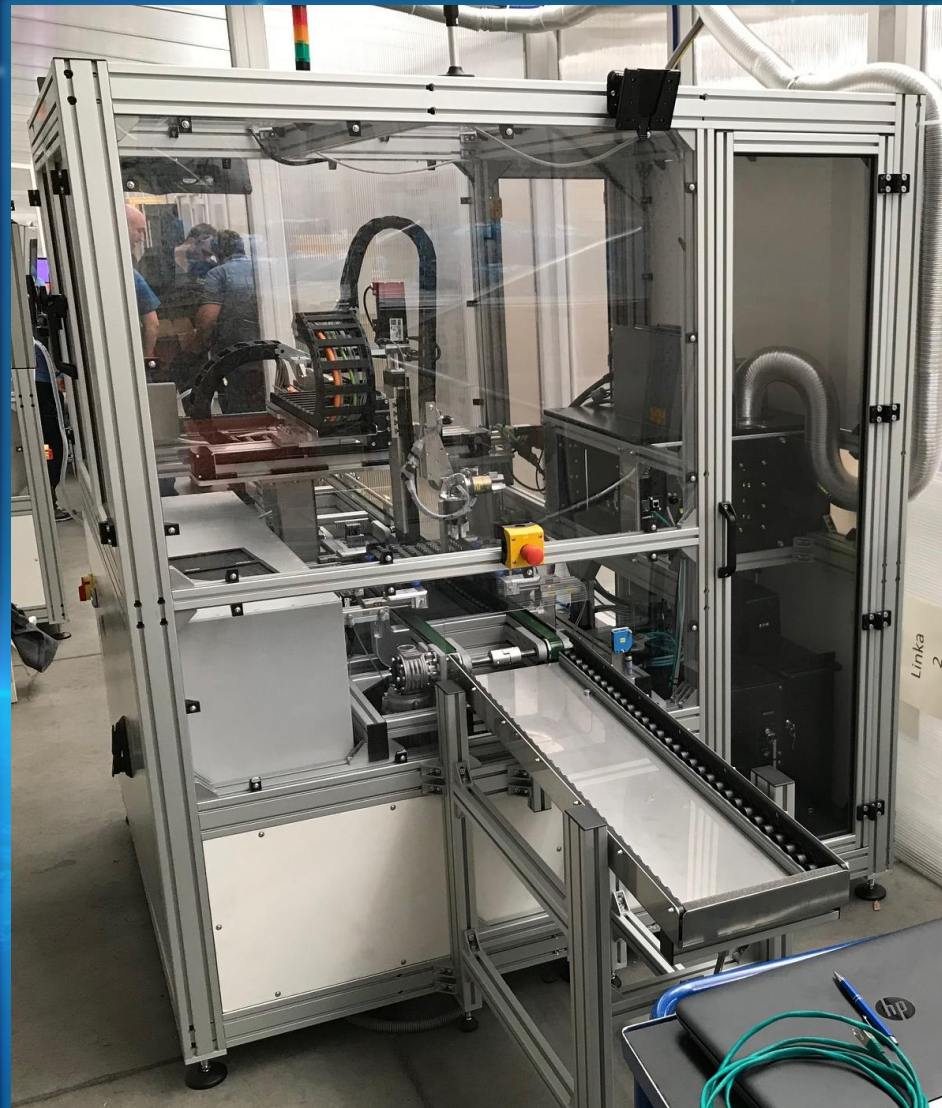
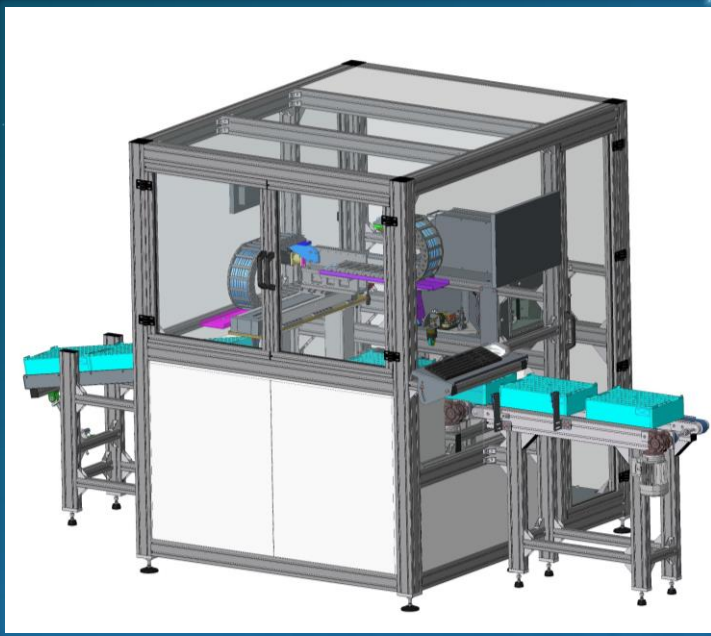

ANTEC – NISSENS : RADIATOR INSTALLATION - MODERNIZATION

MDB
DESIGN
DESIGN

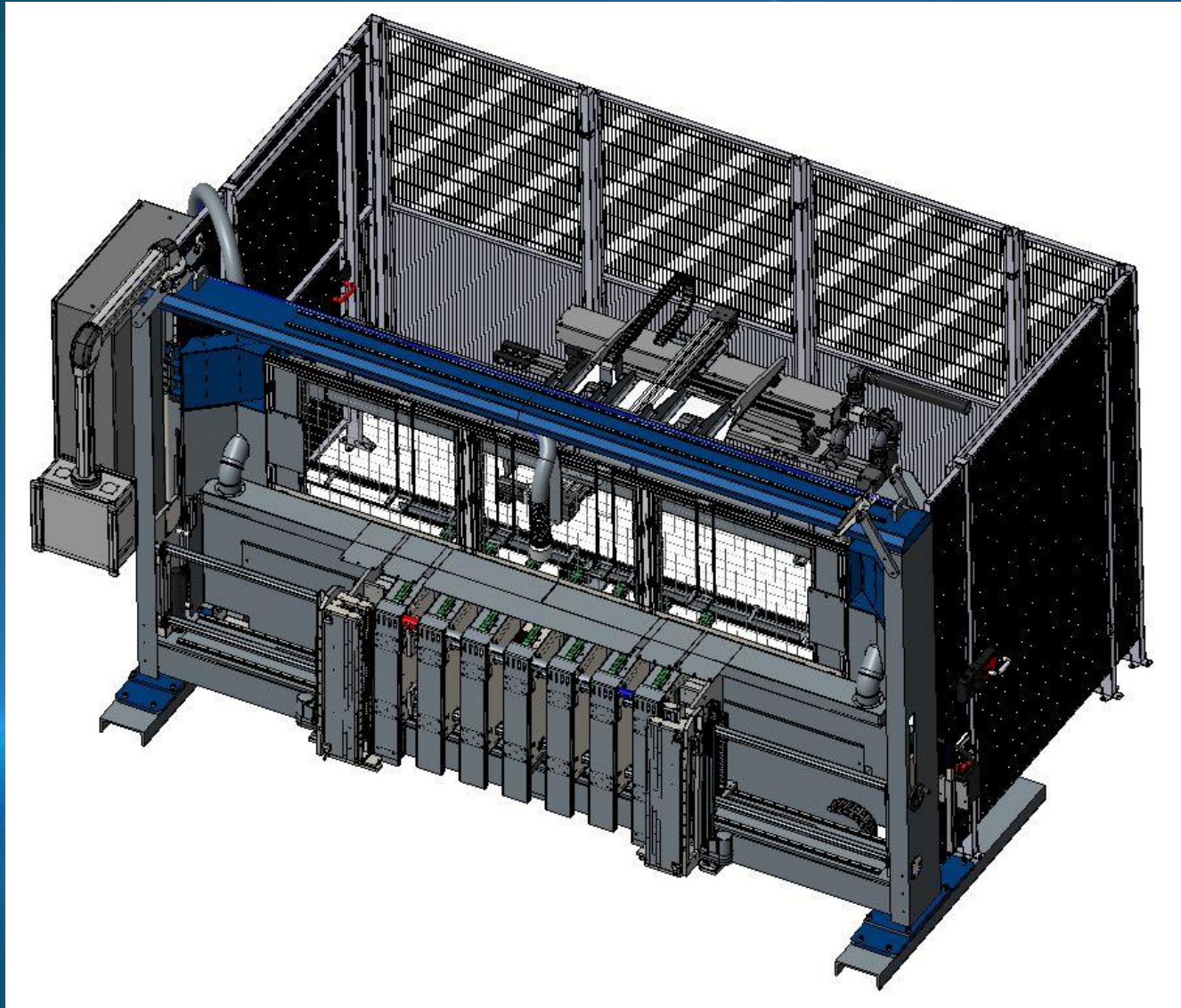

LANÁ, a.s. – ROPE TESTING ROOM, ALLOWS THE FOLLOWING TYPES OF TESTS

- Tensile tests, Creep test, Stress strain, Test fixtures.

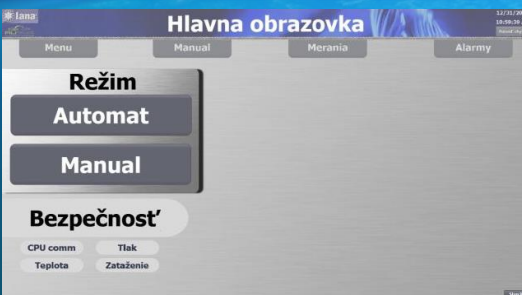
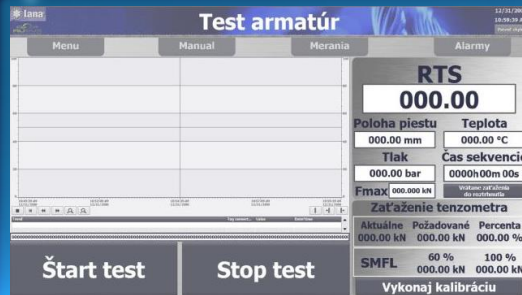
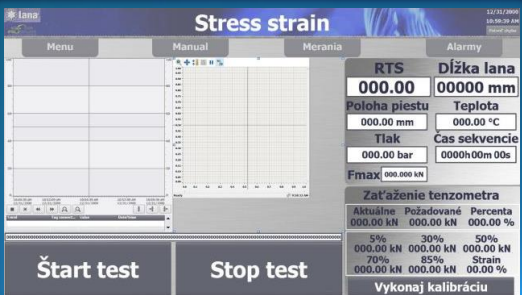
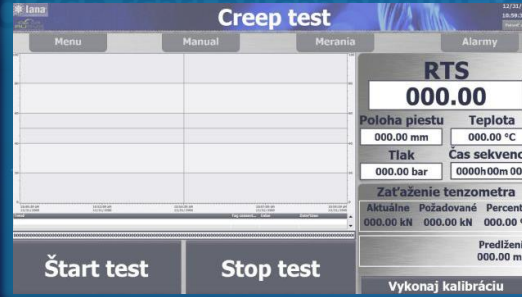

VIPO a.s. – MANIPULATORS FOR RUBBER INDUSTRY

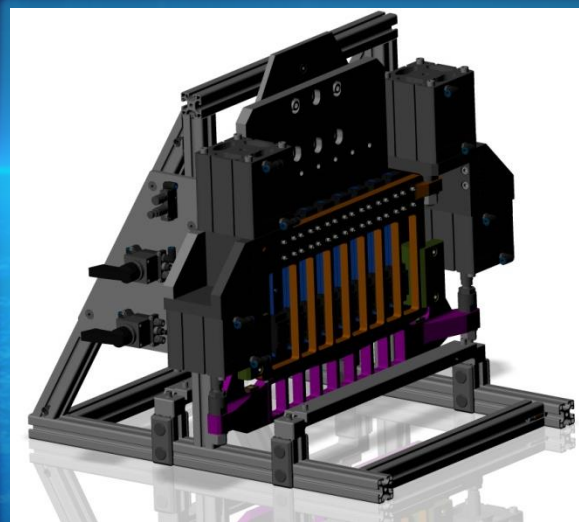
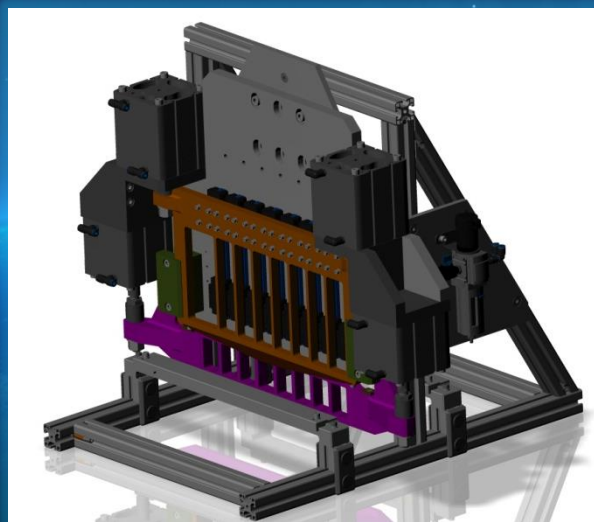
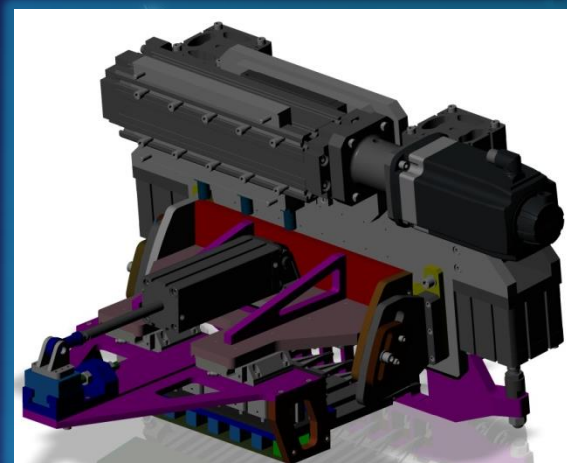
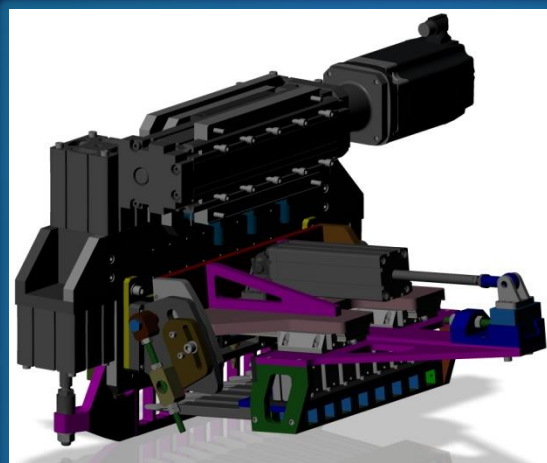
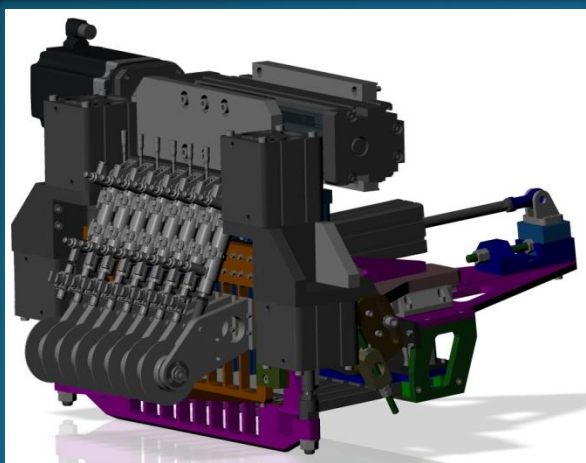

U.S.Steel Košice, s.r.o. – BIGGER PRODUCTION TECHNOLOGY UNITS

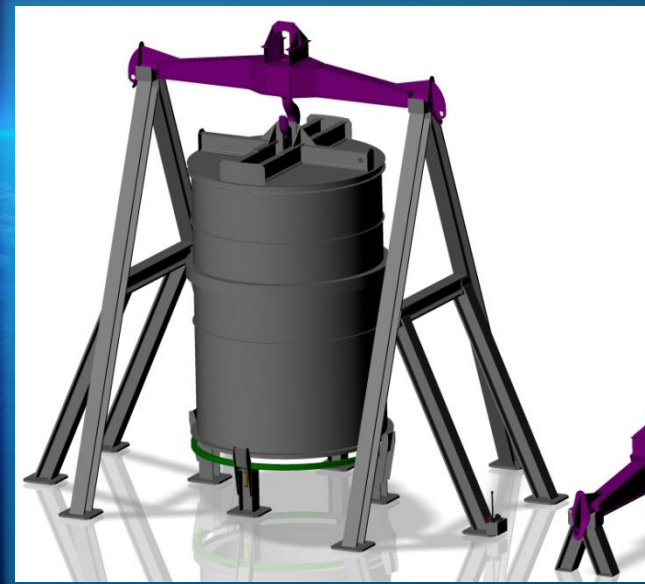
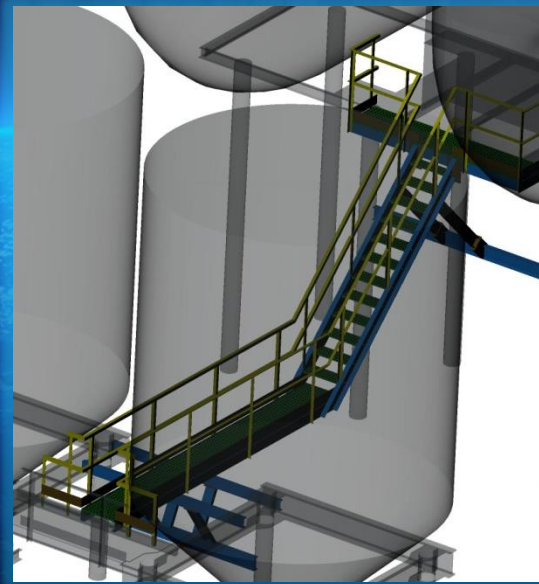
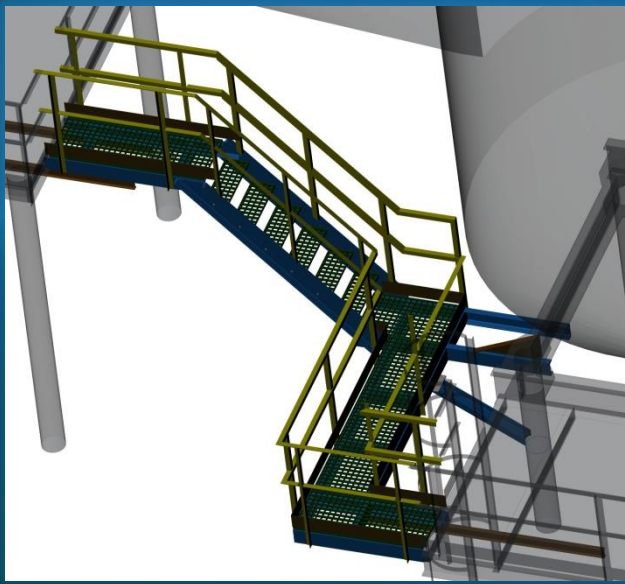
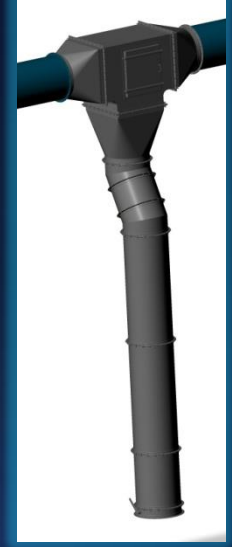
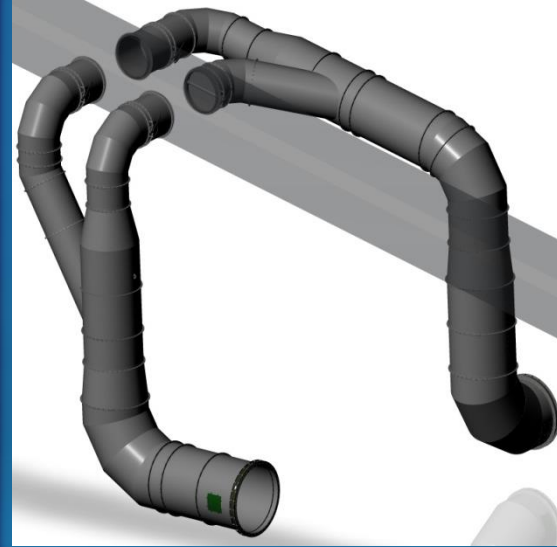
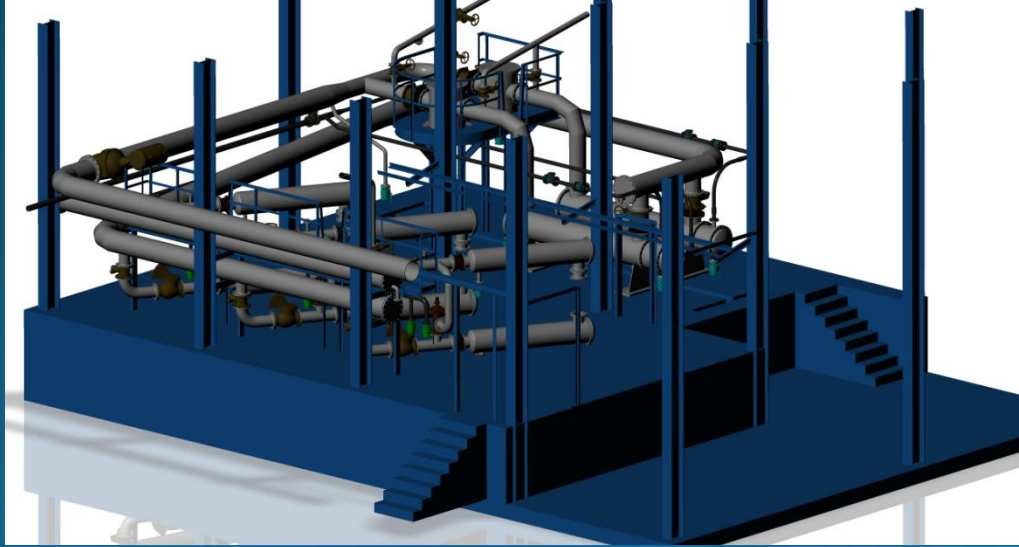

U.S.Steel Košice, s.r.o. – SMALLER PRODUCTION TECHNOLOGY UNITS,
MANIPULATORS, CONVEYORS, PREPARATIONS WITH SAFETY SURVEYS...

MDR
DESIGN
DESIGN

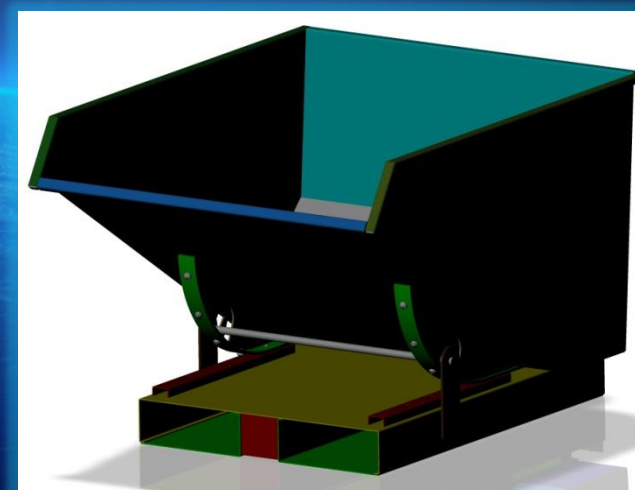
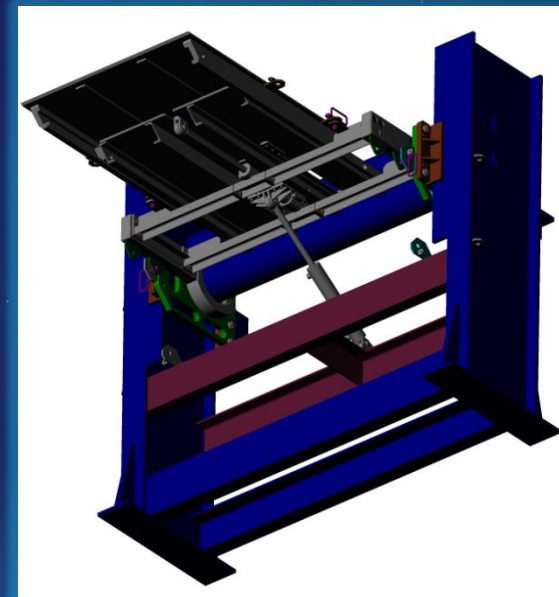
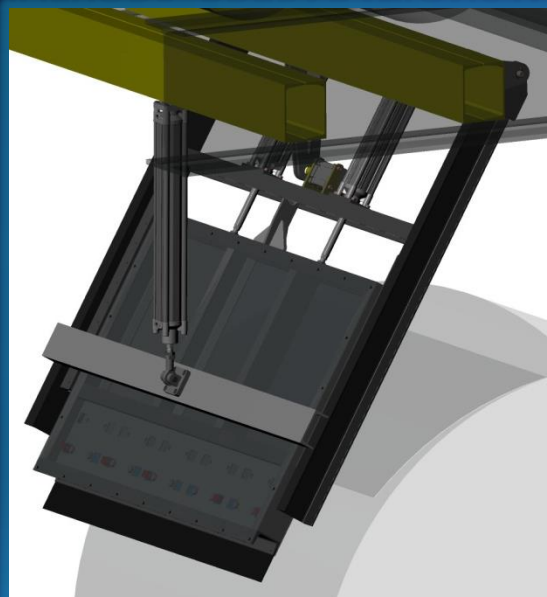
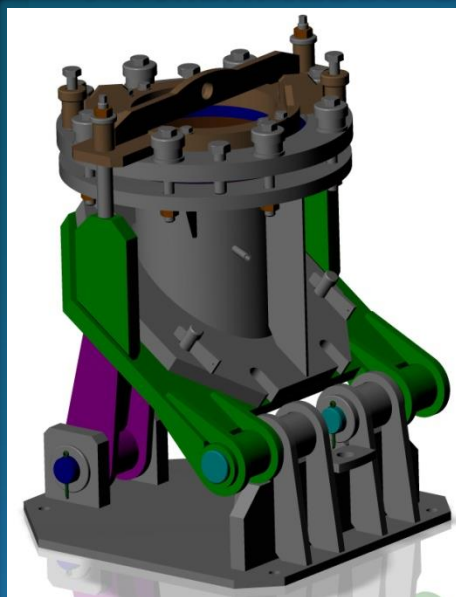

STRESS ANALYSIS - FEM



Displacement Mag (WCS)
(mm)
Deformed
Max Disp 2.7164E+00
Scale 4.8225E+01
Loadset:LoadSet2: MODEL_VOZIKA_UPRAVENY

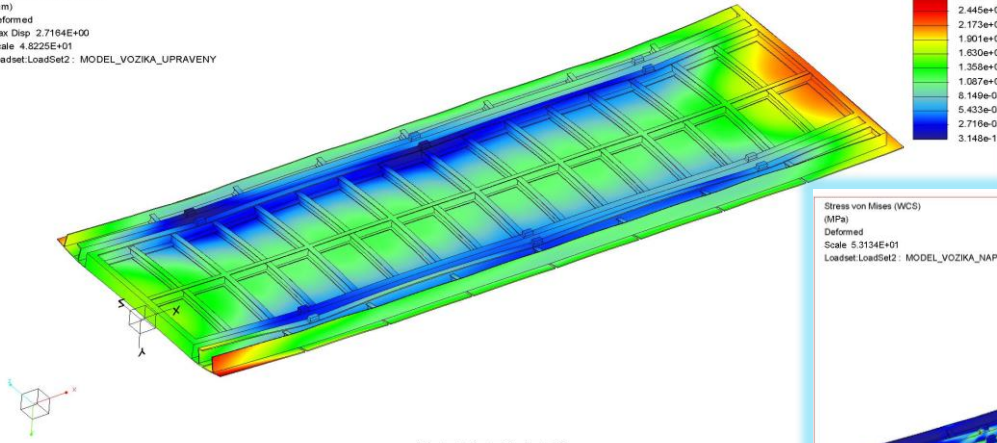

"Window2" - Analysis2 - Analysis2

Stress von Mises (WCS)
(MPa)
Deformed
Scale 5.3134E+01
Loadset:LoadSet2: MODEL_VOZIKA_NAPRIEC

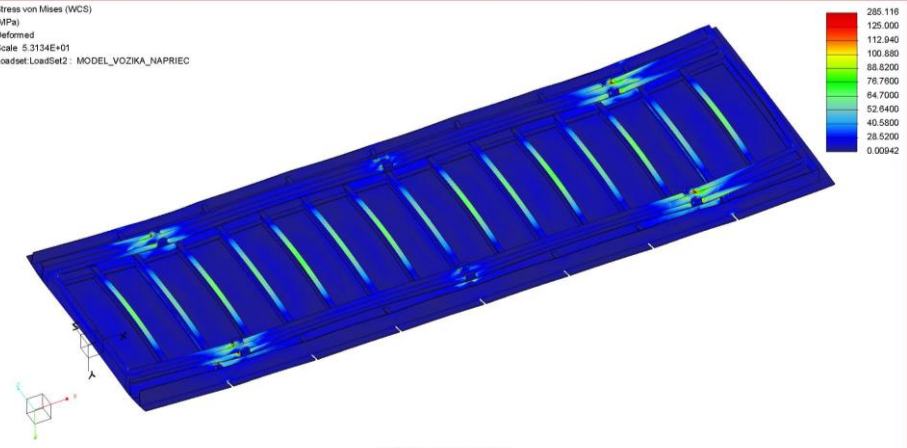

"Window2" - Analysis2 - Analysis2

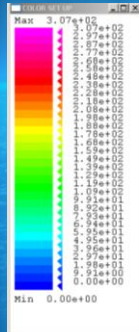
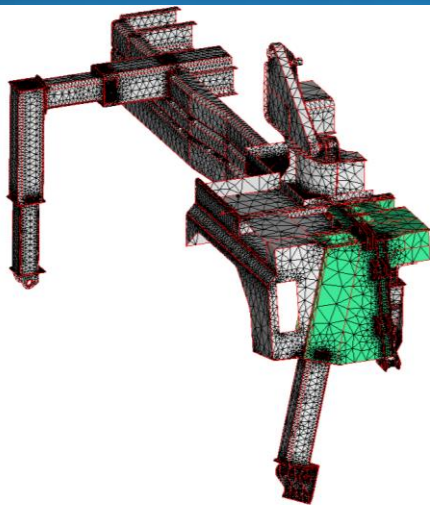

Func: Von Mises Stress [N / mm²] Analyses: all
Min: 0 Max: 307.661738

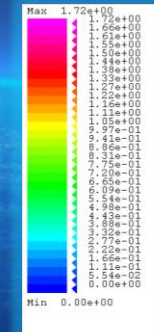
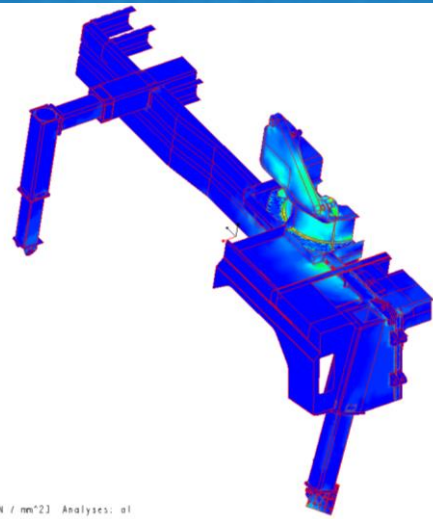

Func: Translational Displacement, Magnitude [mm] Analyses: all

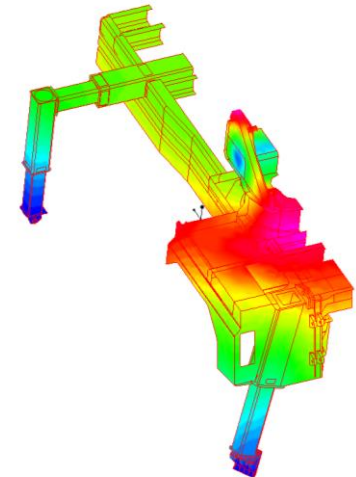

OPTIMIZATION AND MODERNIZATION OF MACHINERY AND EQUIPMENT IN TERMS OF FUNCTIONALITY, PRODUCTION, CHANGES TO THE MATERIALS, OPTIMIZATION IN TERMS OF ALLOWABLE STRESS.

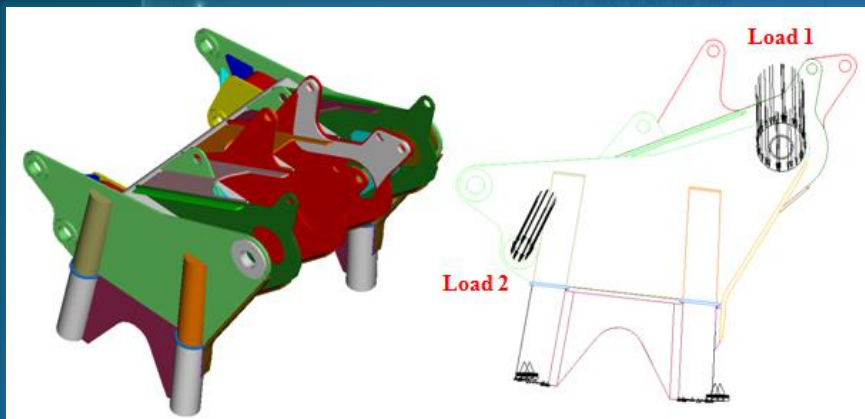

Primary solution

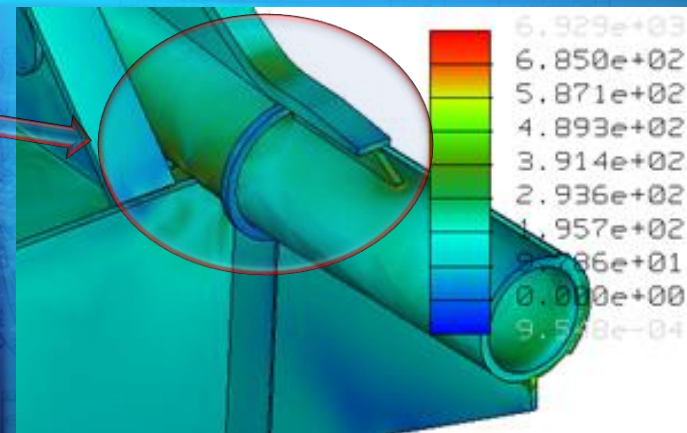
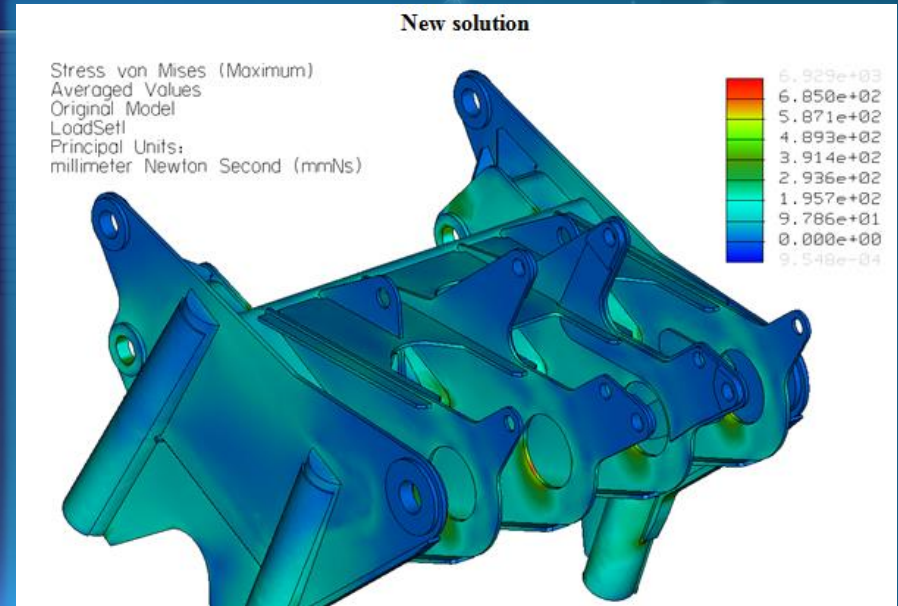
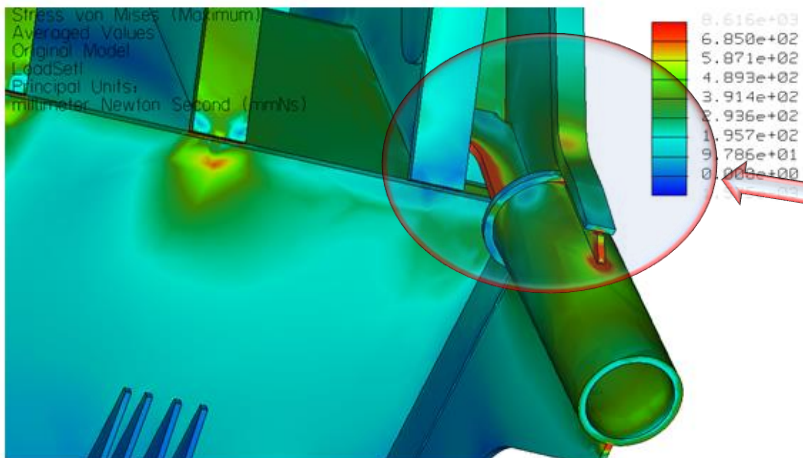

Transmission with a rolling elimination device - THOR. Information – magazine Strojárstvo/2013/str,74-75

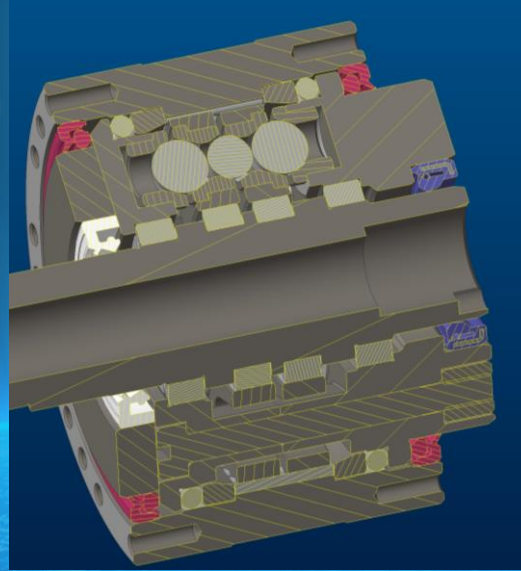
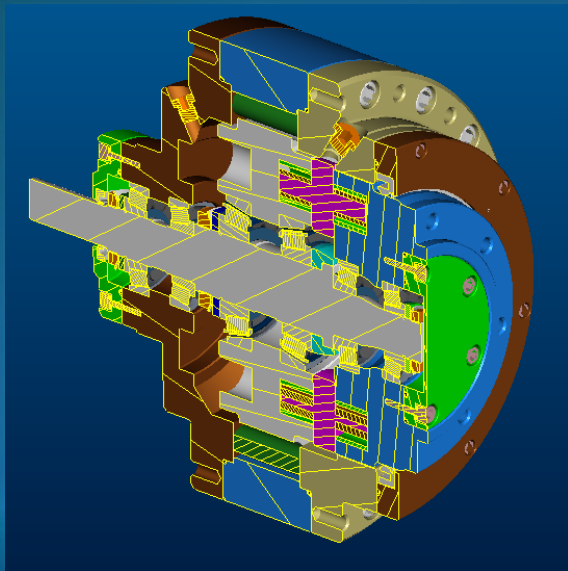

SLOVENSKÁ REPUBLIKA		(11) Číslo dokumentu:
SK		284 375
		(13) Druh dokumentu: B6
ÚRAD PRIEMYSELNÉHO VLASTNÍCTVA SLOVENSKEJ REPUBLIKY		(51) Int. CL ⁷ : F16H 1/32
(19) PATENTOVÝ SPIS	(21) Číslo prihlášky: 595-2000 (22) Dátum podania prihlášky: 25. 4. 2000 (24) Dátum nadobudnutia účinkov patentu: 4. 2. 2005 Vestník UPV SR č.: 2/2005 (31) Číslo prioritnej prihlášky: (32) Dátum podania prioritnej prihlášky: (33) Krajina alebo regionálna organizácia priority: (40) Dátum zverejnenia prihlášky: 9. 1. 2003 Vestník UPV SR č.: 1/2003 (47) Dátum sprístupnenia patentu verejnosti: 26. 1. 2005 (62) Číslo pôvodnej prihlášky v prípade vylúčenej prihlášky: (86) Číslo podania medzinárodnej prihlášky podľa PCT: (87) Číslo zverejnenia medzinárodnej prihlášky podľa PCT:	(12) INTERNATIONAL APPLICATION PUBLISHED UNDER THE PATENT COOPERATION TREATY (PCT)
(19) World Intellectual Property Organization International Bureau		(10) International Publication Number WO 01/86170 A1
(43) International Publication Date 15 November 2001 (15.11.2001)		

GEARBOX „THOR“ AS A REPLACEMENT FOR THESE TYPES GEARBOXES

MDB
DESIGN
DESIGN

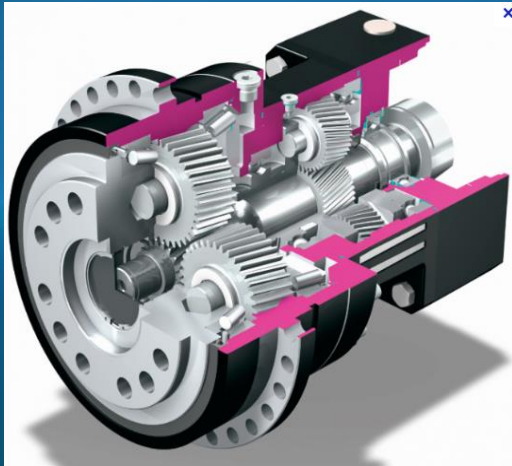

Actuator THOR V12R

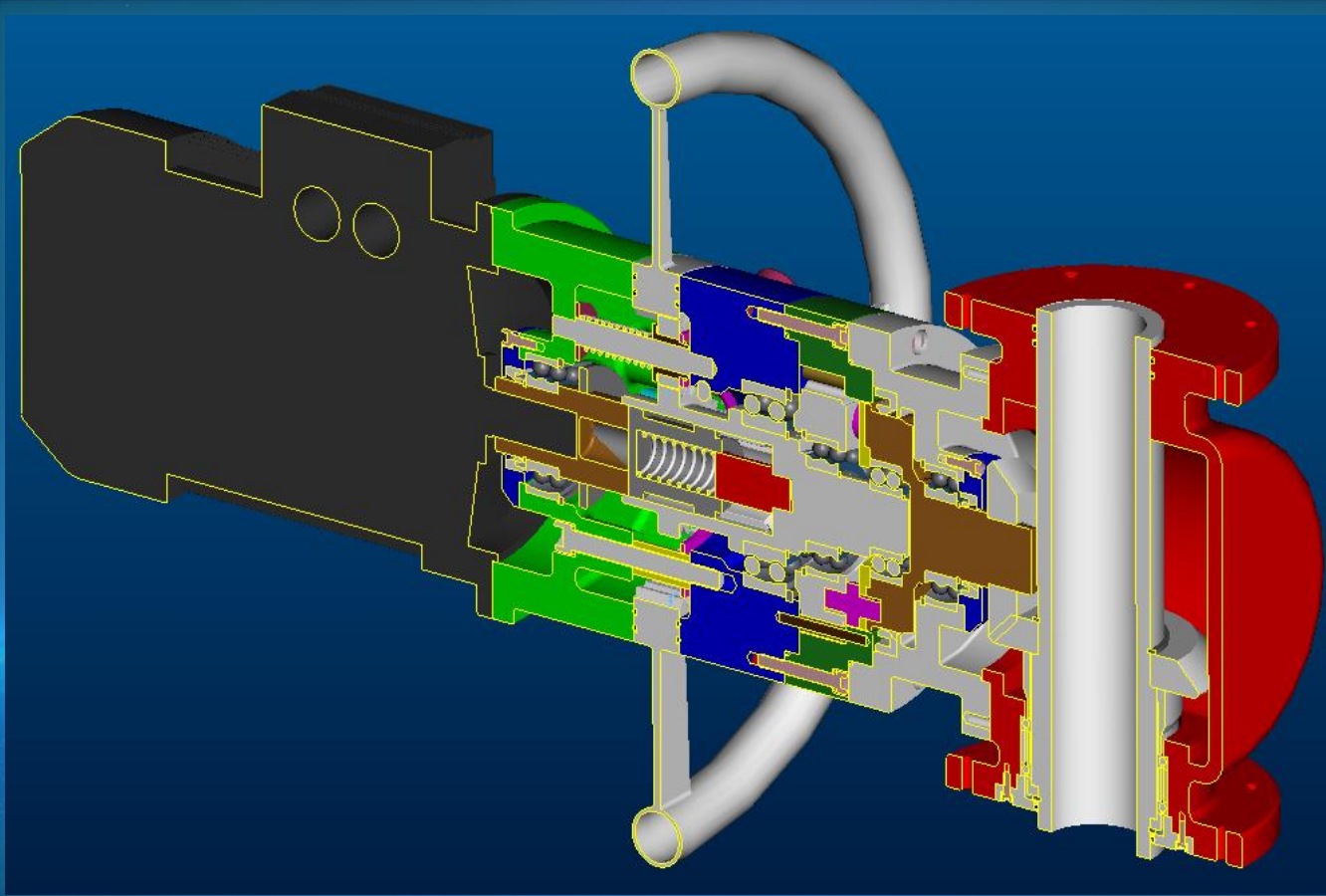



We can realize, what nobody can promise you.

